

Three-phase high-voltage asynchronous machines
with integral air-/air tube-type heat exchanger
up to 17,000 kW

High-voltage machines with integral air/air tube-type heat exchanger

...suits made to measure or off the peg, up to 17,000 kW

Schorch tube-cooled machines are suitable for a wide variety of applications and operating conditions.

A well-proven design, subject to continuous development and improvement, tried and tested in a vast number of applications worldwide under the most difficult operating and site conditions.

Specific variations with modified electrical or mechanical parameters are the result of long and close co-operation with leading manufacturers of driving and driven machines.

If there is a drive problem, consult with us.



Pump drives 1,200 kW 6.6 kV 2pole, in a drinking-water supply

4/0144



Blower drives 1,500 kW 6.6 kV 4pole, in a power station

1/0778

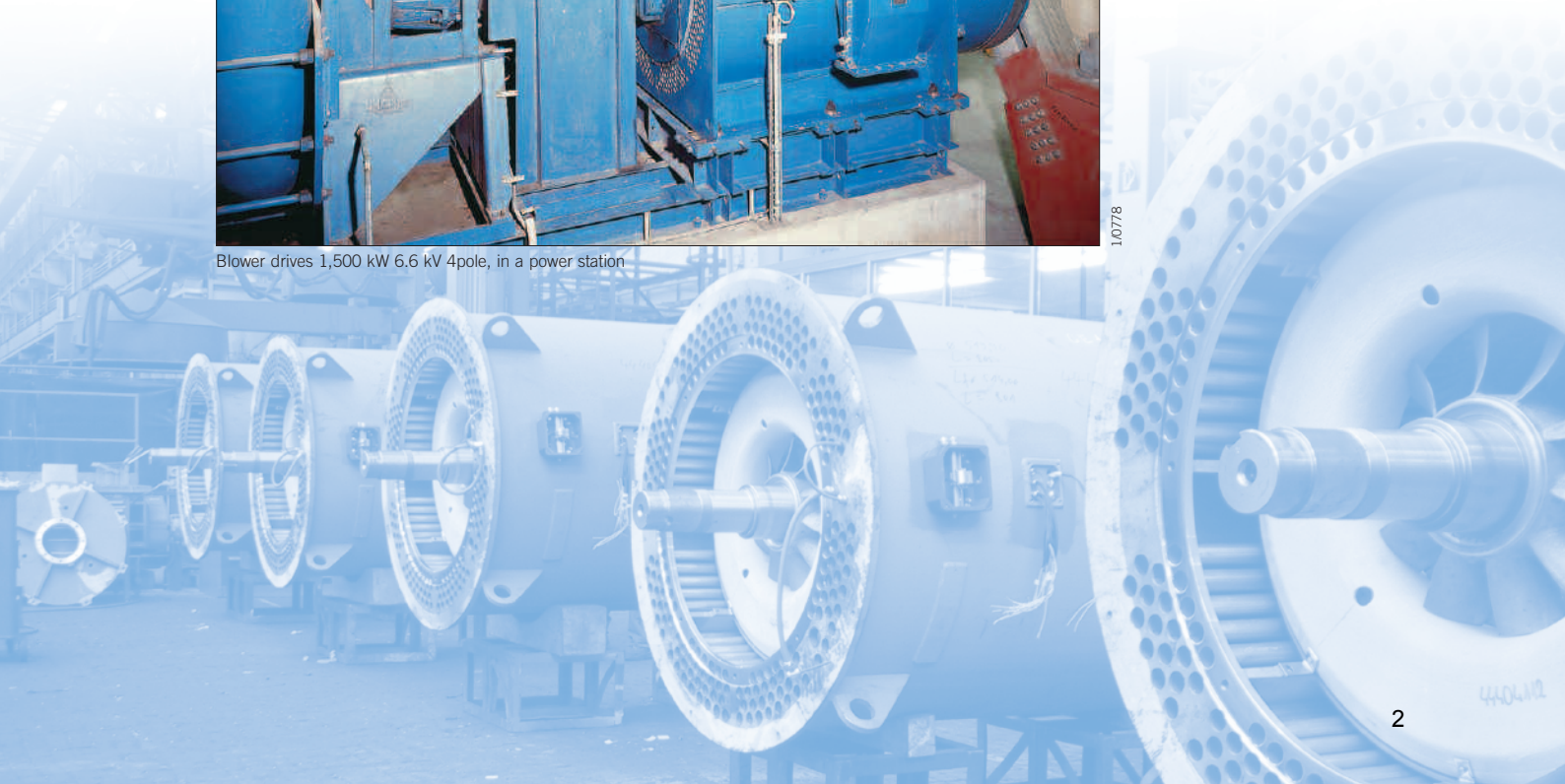

Design

- To relevant standards: IEC, VDE, DIN, ISO, EN
- With squirrel-cage or slipring rotor
- Degree of protection IP 55 / IP 65
Cooling method IC511, suitable for both indoor and outdoor installation
- Non Sparking to EN 60079-15
- Type of protection Exe and Exp to EN
- Rated voltages from 2 to 15 kV
- Rated frequency 50 or 60 Hz
- Converter-fed or connected to the system
- Number of poles $2p=2$ to 8 (higher number of poles on request)
- Construction IM B3 and IM V1 (others on request)
- Design can be modified to meet customer's specification
- Motors can be designed for voltages < 1000 V, or for converter-fed operation

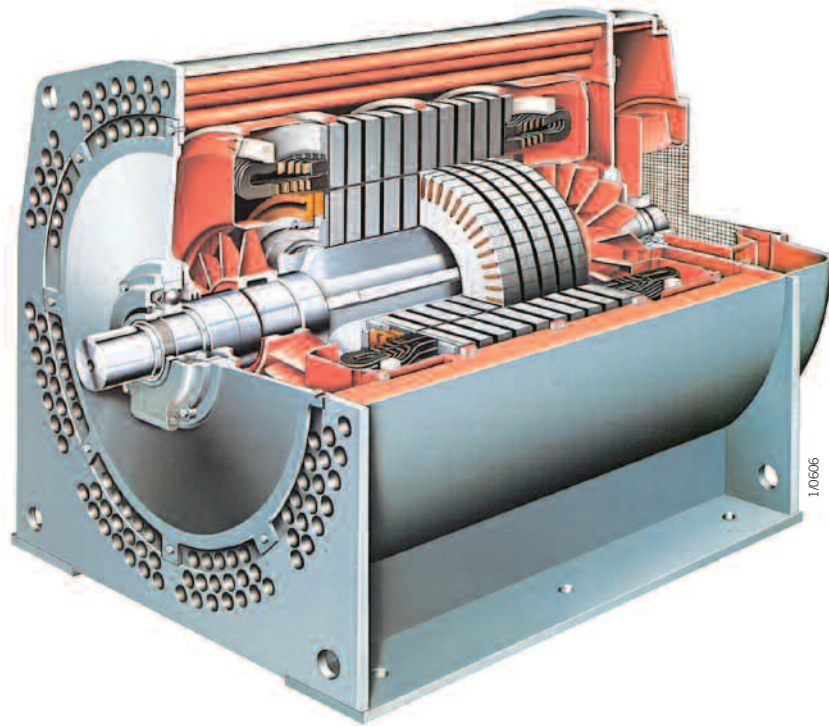

Rated outputs at 6 kV, 50 Hz

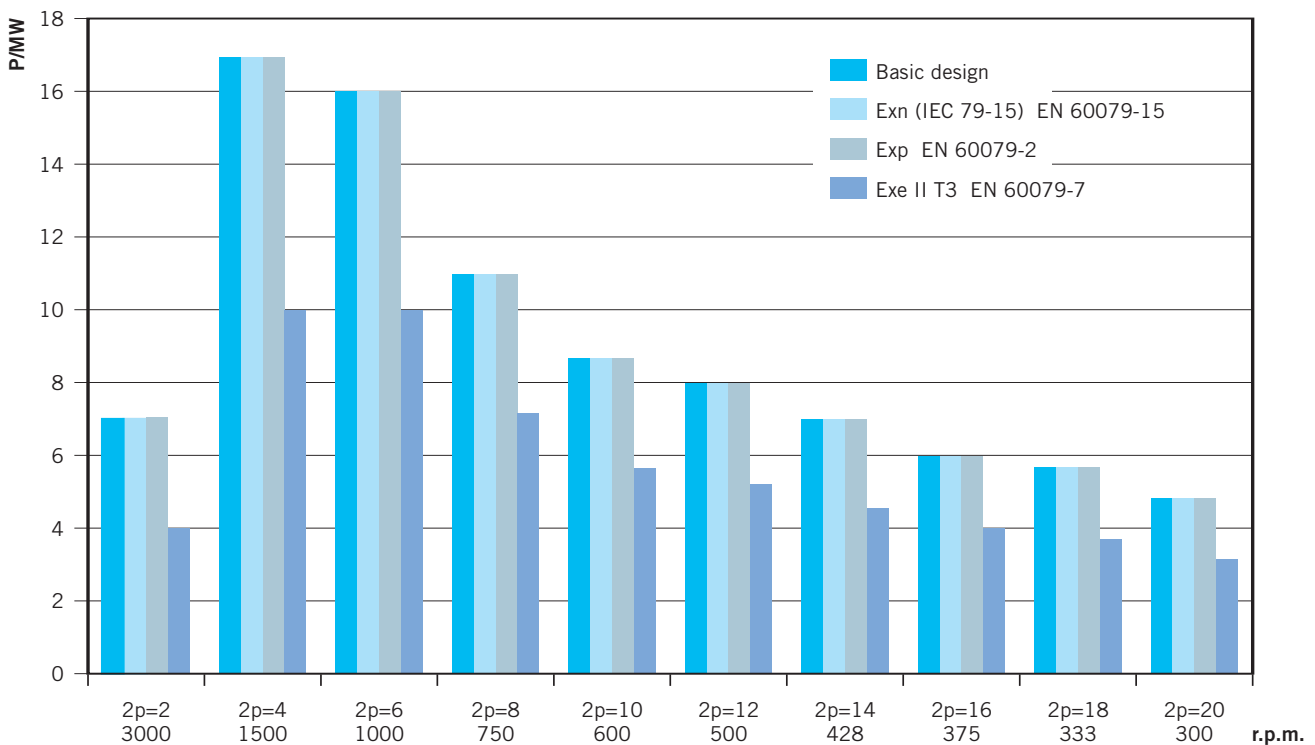

Frame and corrosion protection

Frame

Compact and rigid welded fabrication. The load-carrying frame consists of two end plates, connected by strong ribs. Ribs are braced against each other and are connected to the frame mantle. With horizontal machines, further rigidity is provided by the motor feet.

Cooling tubes of stainless steel are expanded into the end plates.

Slipring motors have a separate slipring housing.

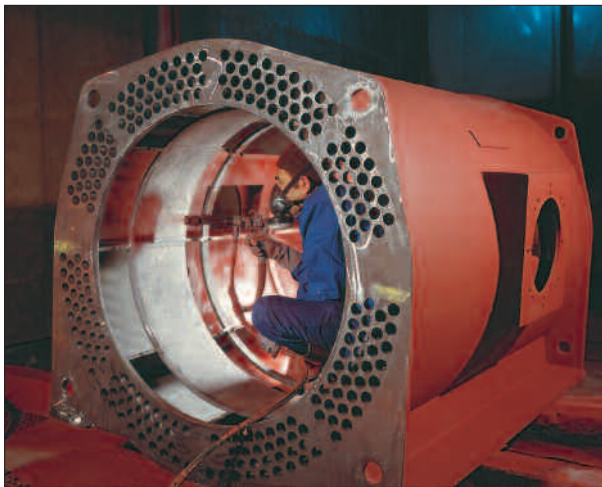
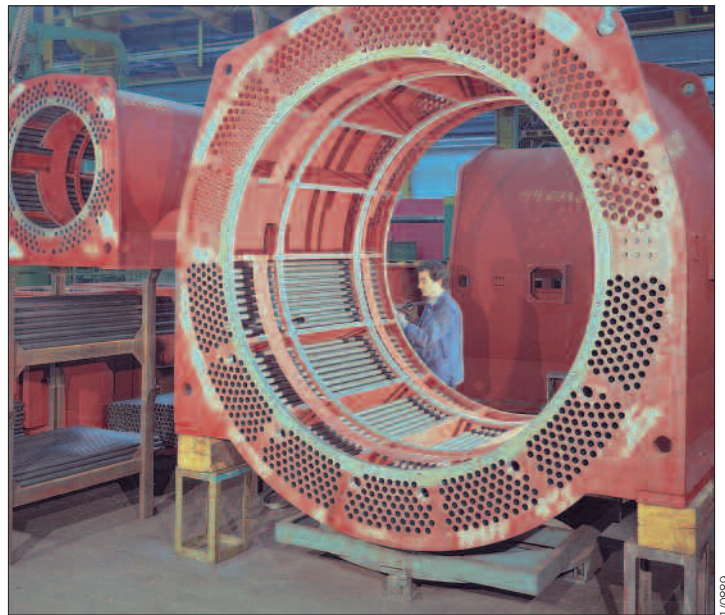

Corrosion protection

Schorch paint systems are well tried and tested. They do not contain any lead, heavy metals or silicone.

Prior to painting, all surfaces are thoroughly sand-blasted. With basic-design machines, the paint system consists of a coat of primer, an intermediate and a finishing coat, standard shade is RAL 7031.

This paint system is suitable for both indoor and outdoor installation, including industrial and sea atmospheres. It is resistant to light, and to temperatures from $-40\text{ }^{\circ}\text{C}$ to $+120\text{ }^{\circ}\text{C}$ (for short periods up to $180\text{ }^{\circ}\text{C}$), non-porous, and resistant to shock and wear.

For specific operating and site conditions, special paint systems are available.



The type of bearings to be used is determined by the construction, the speed, the output and any additional loads of the motor. Depending on these parameters or the customer's specification, antifriction or sleeve bearings are provided.

Anti-friction bearings

Our motors in basic design are fitted with Series 2 or 3 antifriction bearings. IM B3 motors in basic design are provided at the D-end with a grooved ball bearing (locating) and the N-end with a pre-loaded grooved ball bearing (non locating).

For particularly high radial loads, all motors can in addition be provided with cylindrical roller bearing at the D-end.

As shaft seals, felt rings are provided on the motor side of the bearing and V rings on the outside.

Shaft seals are maintenance free and provide protection against dirt and spray water in accordance with degree of protection IP 55.

Lubricators and grease slingers ensure proper lubrication of the bearings. The outer bearing covers are provided with a space for old grease and a grease drain.

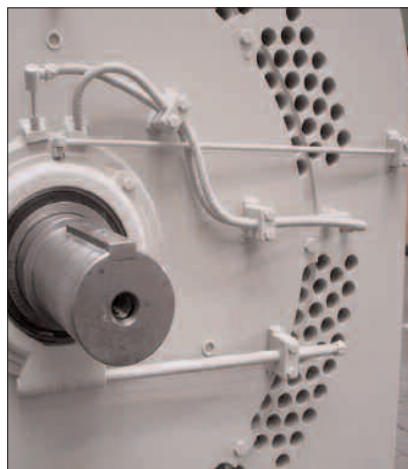

Antifriction bearing with lubricator and grease drain

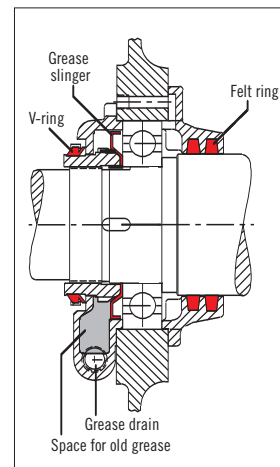

Antifriction bearing arrangement

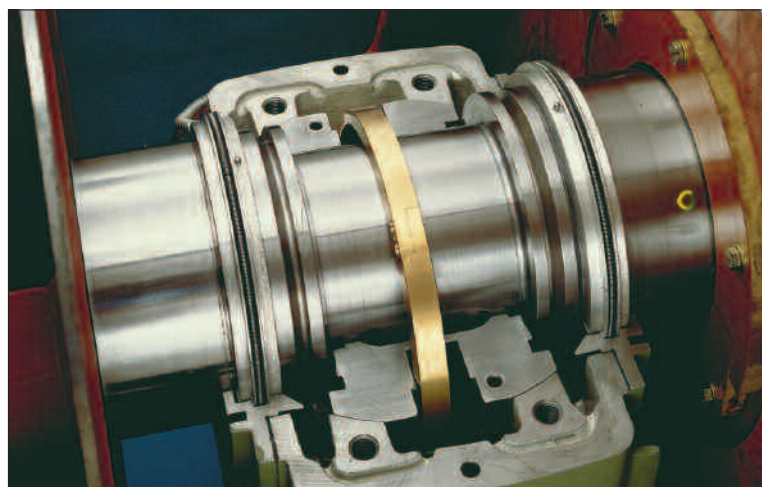

Sleeve bearing with ring oiler

Sleeve bearings

On request, all motors can be fitted with sleeve bearings. All sleeve bearings are of the split, flanged type.

Depending on the bearing load in service, bearing with loose ring oilers (self lubrication) or with force-feed lubrication are used. Subsequent conversion from self to force-feed lubrication is possible.

Sleeve bearings are non-locating. Shaft end float is ± 3 mm. On request, a locating bearing can be provided at the D-end.

On the bearing inside, a floating labyrinth seal and a labyrinth ring is used. The shaft seal on the bearing outside consists of a floating labyrinth and an additional seal - reliable protection both against the ingress of foreign matter and the loss of oil.

Shaft seals are maintenance-free. They protect the bearings against the ingress of dust and spray water, to degree of protection IP55.

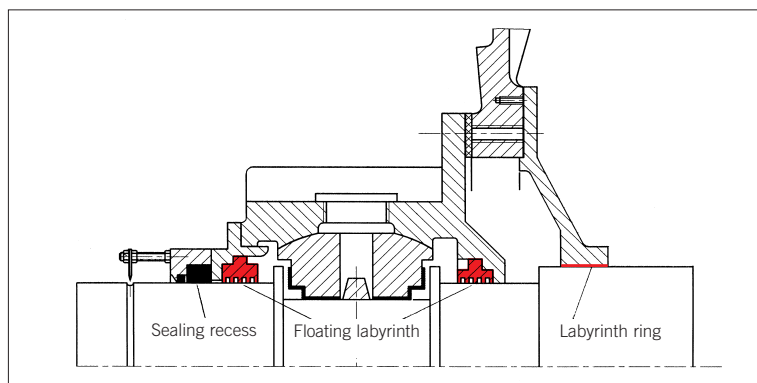

Shaft seals for sleeve bearings

Ventilation and noise

Ventilation system

Tubes, concentrically arranged around the active part, act as air/air heat exchangers. Heat generated within the motor is taken up by the cooling tubes which are cooled by external air.

The internal air circulation with axial air ducts in the shaft and radial air ducts in the active part ensures a near uniform temperature distribution in the motor. Hot spots cannot occur, and the thermal life of the winding is prolonged.

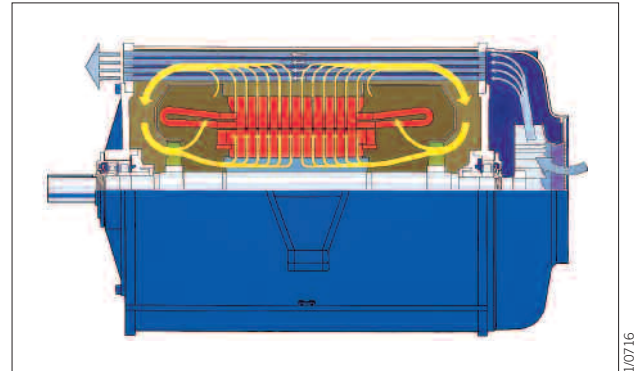

1/0716

Noise

In view of ever more stringent regulations concerning protection of the environment and safety at work, the noise reduction of electrical machines is of particular importance.

From the outset, i. e. already in the basic design, our machines are designed as low-noise machines. This is achieved by an interactive design of all components, such as:

- Frame
- Ventilation System
- Electro-magnetic design
- Bearings

Noise reduction

Where extreme noise requirements are to be met, various additional measures can be taken.

Depending on the machine design and the number of poles, acoustic absorbers for the air inlet and air outlet are used, which offer noise reductions up to 12 dB.

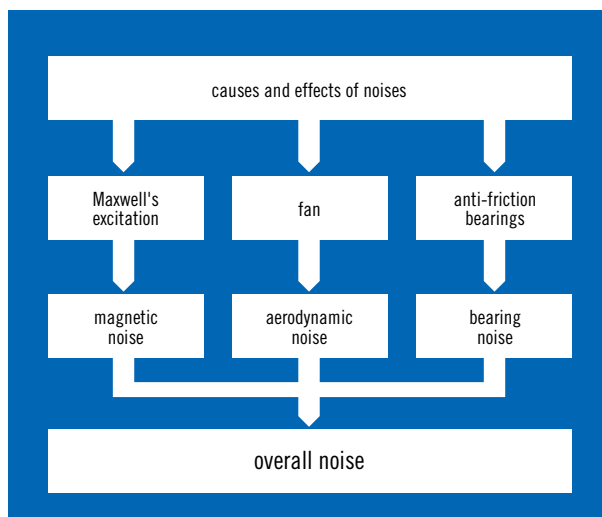

Sources of noise in electrical machines

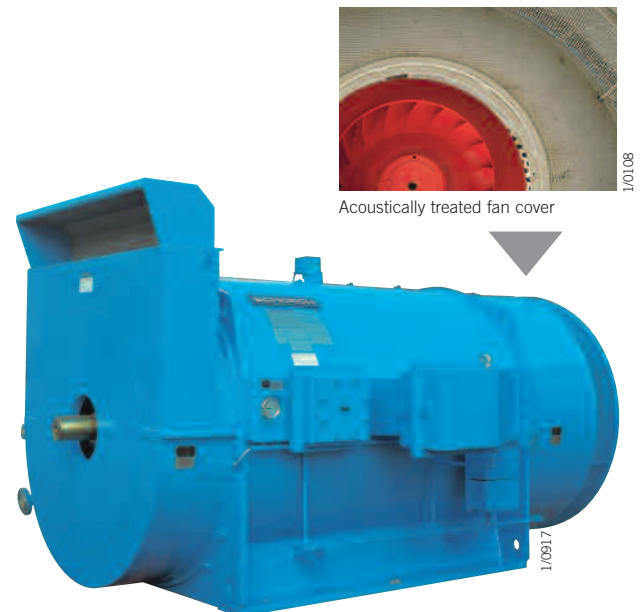

1/0108

1/0917

Motor with air outlet absorber and acoustically treated frame mantle

Developments in the field of insulation led in the 80's to the introduction of the V-Celastik® insulating system. This is a system using the VPI technique which corresponds to Class F.

VPI means that the complete stator (core and windings) is impregnated with artificial resin in a vacuum/pressure process. The result is a winding with excellent thermal, electrical and mechanical properties.

The constantly high quality of the high-voltage insulation is ensured by the latest in manufacturing equipment.

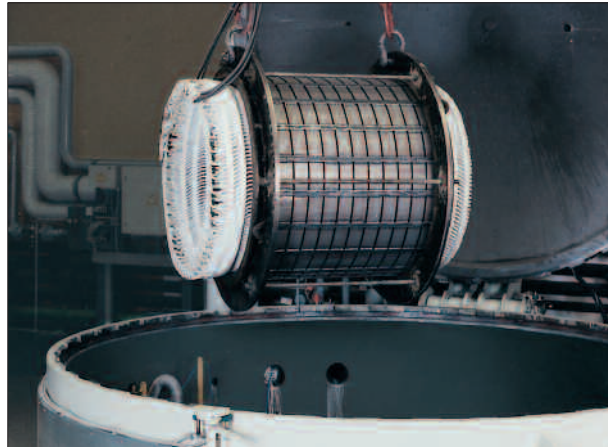

Wound stator prior to impregnation

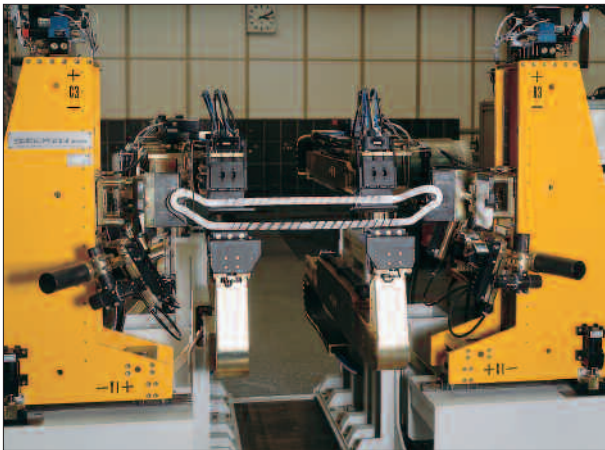

Coil-spreading machine

1/1199

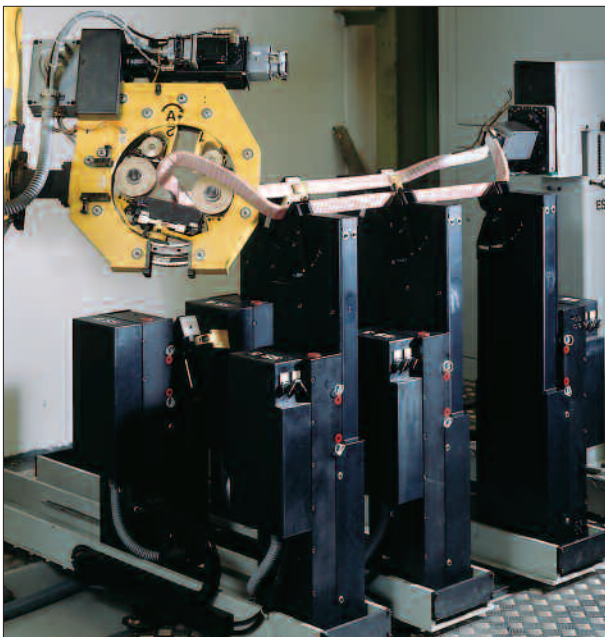

Coil-taping machine

1/1196

Impulse withstand capability

The impulse withstand level of the windings is well above the specified minimum of $4 \times U_N + 5 \text{ kV}$ so that additional protective measures against overvoltages have to be taken only in exceptional cases.

Mechanical stability

Windings are designed to meet all mechanical stresses occurring in service. The bracing of each winding is calculated, using a special computer program developed at Hanover University.

This calculation is based on the highest stresses to be expected, e. g. reconnection against 100 % residual voltage in phase opposition.

Quality assurance

The manufacture of windings is, as is the entire company, subject to a certified QA system to DIN EN ISO 9001.

Materials, manufacturing techniques and processes are continually monitored and the results recorded. Additional tests on winding elements, or complete windings, can be carried out on request.

® Registered Trademark

Squirrel-cage rotor

In the basic design, the deep-bar squirrel-cage winding consists of copper bars, brazed to short-circuiting rings. Depending on rotor stresses, either butt or grooved bar-to-ring joints are used.

The comparatively low resistance of the copper winding results in low current/heat losses and, consequently, in high efficiencies.

The copper bars are driven into the core slots and pinned to ensure absolutely positive seating. This prevents any movement of the cage winding and makes for optimum heat transfer, essential for long acceleration or locked-rotor times.

For higher starting torques, or to meet the requirements of particular torque characteristics, special slot designs can be used.

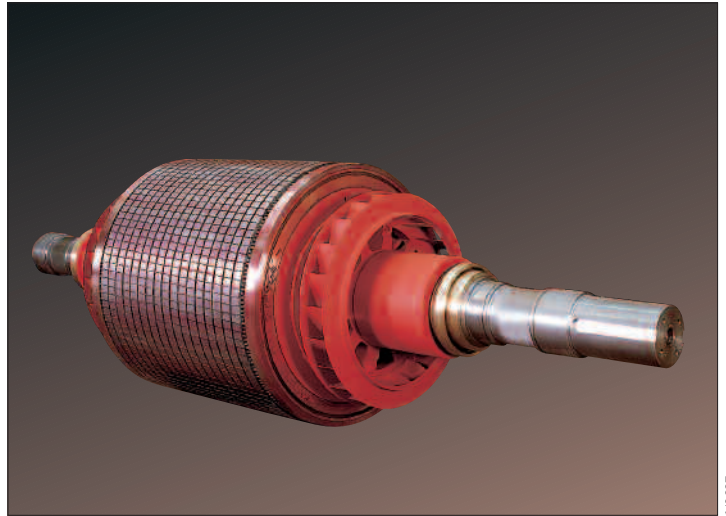

Rotor with copper cage winding

1/0697

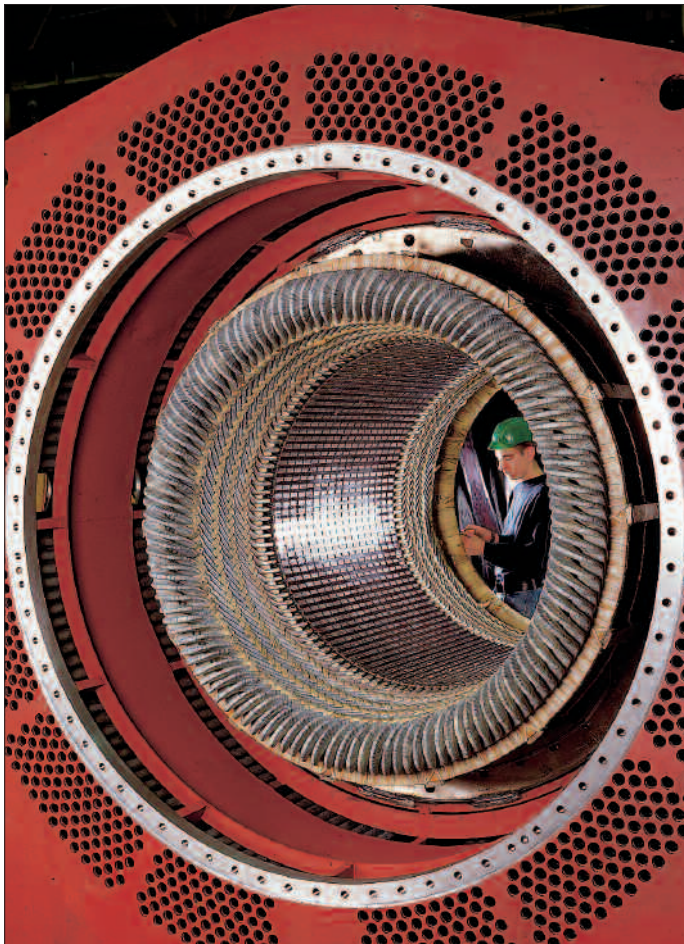

Endwinding

1/0694

Stator winding

The stator winding is a corded two-layer winding. It is connected in star, with the neutral being connected at the winding overhang. The three winding ends are brought out to the terminal box.

The terminal box can be shifted subsequently from left to right or vice versa, without any problems, even at site.

On request, all winding ends can be brought out. In that case, the neutral is formed in a separate terminal box.

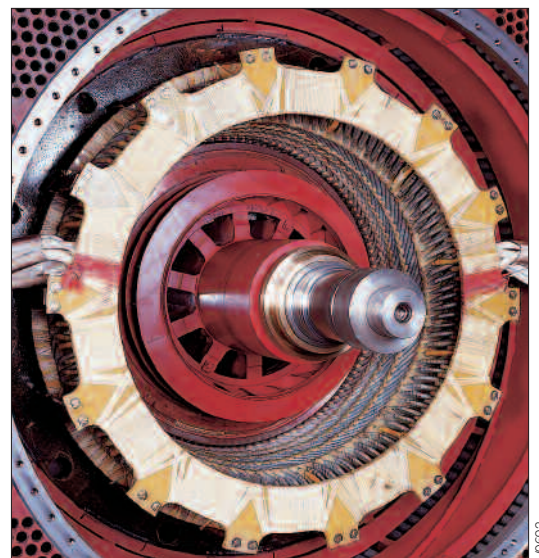

Connecting side of endwinding

1/0692

Operator protection

Terminal boxes have a high short-circuit strength (terminals) and are highly short-circuit-proof (shatterproof).

In the event of a fault, the internal pressure is vented in one direction only. Injuries due to flying debris are prevented.

These properties have been verified in a neutral test laboratory in numerous internal fault tests on an infinite bus.

Electrical and mechanical design

Ample dimensions of the terminal boxes make for simple and safe connection of the supply cables. For the connection, either cable lugs (standard) or terminal clamps (special) are provided. Compound filled cable entries are available on request.

Terminal boxes meet the requirements of degree of protection IP55 to IEC 60529 and protection Ex ell EN 60079-7. All terminal boxes are designed for outdoor installation.

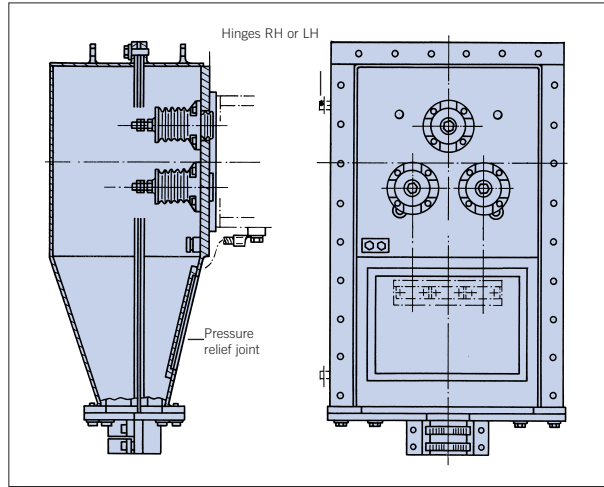

Terminal Box for 10 kV and for fault levels 330 or 800 MVA. Relief joint at the rear



Standard 6 kV terminal box with opened relief joint



Terminal box with 6 kV cast-resin bushings

In order to ensure the highest possible degree of safety, terminal boxes are made of non-splintering material. In addition, cast-resin bushings to DIN 46264 are used, which have a high bending and torsional strength. Pressure relief joints are arranged in such a way that an internal pressure is released either upwards or towards the machine.

Depending on the supply system, tested terminal boxes for the following fault capacities are available:

**200/350/400 MVA up to 6.6 kV or
330/800 MVA up to 11 kV**

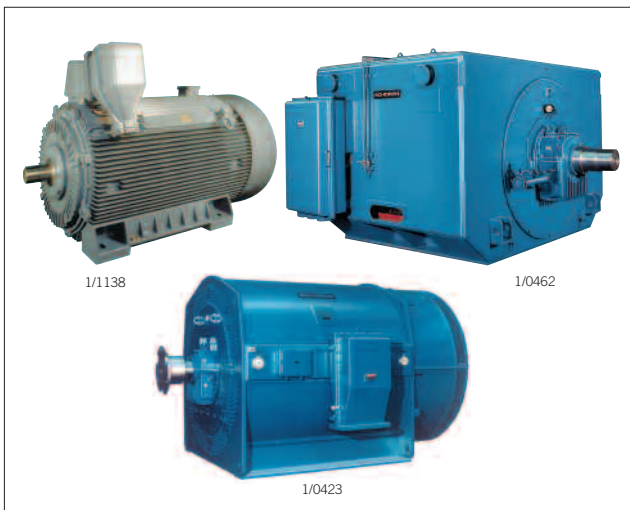

Different terminal box designs

Shatterproofness

In order to ensure shatterproofness of the terminal box, the following minimum conductor cross-sections must be observed:

System fault level	Min. cond. cross-section Cu in mm ² at U _N =	
	6kV	10kV
MVA		
<200	70	70
>200-250	95	70
>250-350	150	95
>350-500	185	150
>500-800	-	185

On request, terminal plates can be provided for cable connectors IP66 for up to 11 kV and up to 400 A.

Monitoring, Design variants

Monitoring devices

On basic-design machines, holes are provided in the bearing housings for the installation of thermal sensors. Holes for installation of vibration sensors on request.

Where the motor is covered by an overall monitoring system, sensors/monitoring devices can be provided for the continuous monitoring/indication of electrical, thermal or mechanical data.

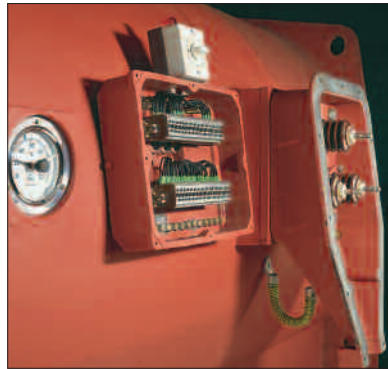

1/0101

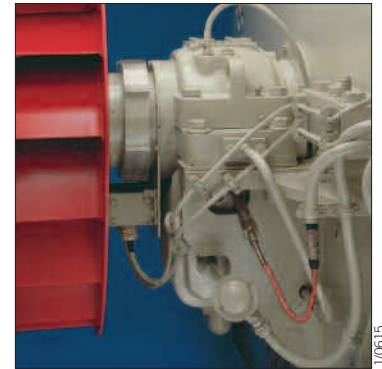

1/0615

Design variants



1/1202a

Piston compressor drive, 2,150 kW, 11 kV, 20-pole, IM D2



1/1179

Shredder drive, 1,120 kW, 6.6 kV, 10-pole, star-delta starting, with turbo coupling



1/1088

Pump drive, 3,500 kW, 6 kV, 4-pole, sleeve bearings with force-feed lubrication, Pressurized enclosure Exp



1/0475

Pump drive, 600 kW, 6 kV, 2-pole, IM V1, connection via cable plugs



SCHORCH

ATB Schorch GmbH
Breite Straße 131 · 41238 Mönchengladbach
Germany
Phone +49 2166 925-0
Fax +49 2166 925-100
mail@schorch.de
www.schorch.de